

# WHELEN<sup>®</sup>

## ENGINEERING COMPANY

51 Winthrop Road  
Chester, Connecticut 06412-0684  
Phone: (860) 526-9504  
Internet: [www.whelen.com](http://www.whelen.com)  
Sales e-mail: [autosale@whelen.com](mailto:autosale@whelen.com)  
Customer Service e-mail: [custserv@whelen.com](mailto:custserv@whelen.com)

Installation Guide:  
Outer Edge<sup>®</sup> SOLO<sup>™</sup> LC Traffic Advisor<sup>™</sup>  
2014 - 2021 Tahoe & 2014 - 2019 Explorer  
2020 Ford Interceptor SUV

### Warnings to Installers

Whelen's emergency vehicle warning devices must be properly mounted and wired in order to be effective and safe. Read and follow all of Whelen's written instructions when installing or using this device. Emergency vehicles are often operated under high speed stressful conditions which must be accounted for when installing all emergency warning devices. Controls should be placed within convenient reach of the operator so that they can operate the system without taking their eyes off the roadway. Emergency warning devices can require high electrical voltages and/or currents. Properly protect and use caution around live electrical connections. Grounding or shorting of electrical connections can cause high current arcing, which can cause personal injury and/or vehicle damage, including fire. Many electronic devices used in emergency vehicles can create or be affected by electromagnetic interference. Therefore, after installation of any electronic device it is necessary to test all electronic equipment simultaneously to insure that they operate free of interference from other components within the vehicle. Never power emergency warning equipment from the same circuit or share the same grounding circuit with radio communication equipment. All devices should be mounted in accordance with the manufacturer's instructions and securely fastened to vehicle elements of sufficient strength to withstand the forces applied to the device. Driver and/or passenger air bags (SRS) will affect the way equipment should be mounted. This device should be mounted by permanent installation and within the zones specified by the vehicle manufacturer, if any. Any device mounted in the deployment area of an air bag will damage or reduce the effectiveness of the air bag and may damage or dislodge the device. Installer must be sure that this device, its mounting hardware and electrical supply wiring does not interfere with the air bag or the SRS wiring or sensors. Mounting the unit inside the vehicle by a method other than permanent installation is not recommended as unit may become dislodged during swerving; sudden braking or collision. Failure to follow instructions can result in personal injury. Whelen assumes no liability for any loss resulting from the use of this warning device. **PROPER INSTALLATION COMBINED WITH OPERATOR TRAINING IN THE PROPER USE OF EMERGENCY WARNING DEVICES IS ESSENTIAL TO INSURE THE SAFETY OF EMERGENCY PERSONNEL AND THE PUBLIC.**

### Warnings to Users

Whelen's emergency vehicle warning devices are intended to alert other operators and pedestrians to the presence and operation of emergency vehicles and personnel. However, the use of this or any other Whelen emergency warning device does not guarantee that you will have the right-of-way or that other drivers and pedestrians will properly heed an emergency warning signal. Never assume you have the right-of-way. It is your responsibility to proceed safely before entering an intersection, driving against traffic, responding at a high rate of speed, or walking on or around traffic lanes. Emergency vehicle warning devices should be tested on a daily basis to ensure that they operate properly. When in actual use, the operator must ensure that both visual and audible warnings are not blocked by vehicle components (i.e.: open trunks or compartment doors), people, vehicles, or other obstructions. It is the user's responsibility to understand and obey all laws regarding emergency warning devices. The user should be familiar with all applicable laws and regulations prior to the use of any emergency vehicle warning device. Whelen's audible warning devices are designed to project sound in a forward direction away from the vehicle occupants. However, because sustained periodic exposure to loud sounds can cause hearing loss, all audible warning devices should be installed and operated in accordance with the standards established by the National Fire Protection Association.

### Safety First

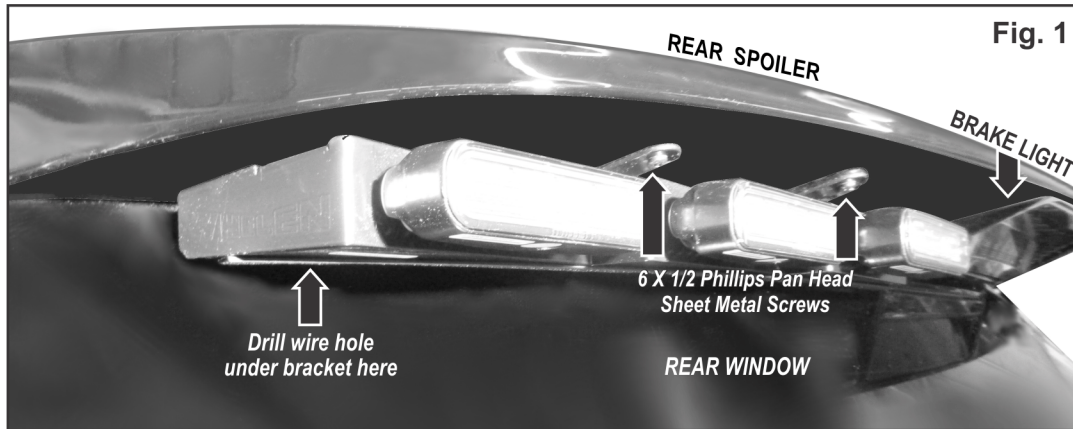
This document provides all the necessary information to allow your Whelen product to be properly and safely installed. Before beginning the installation and/or operation of your new product, the installation technician and operator must read this manual completely. Important information is contained herein that could prevent serious injury or damage.

**⚠ WARNING:** This product can expose you to chemicals including Lead which is known to the State of California to cause cancer and birth defects or other reproductive harm. For more information go to [www.P65Warnings.ca.gov](http://www.P65Warnings.ca.gov).

- **Proper installation of this product requires the installer to have a good understanding of automotive electronics, systems and procedures.**
- **Whelen Engineering requires the use of waterproof butt splices and/or connectors if that connector could be exposed to moisture.**
- **Any holes, either created or utilized by this product, should be made both air- and watertight using a sealant recommended by your vehicle manufacturer.**
- **Failure to use specified installation parts and/or hardware will void the product warranty.**
- **If mounting this product requires drilling holes, the installer MUST be sure that no vehicle components or other vital parts could be damaged by the drilling process. Check both sides of the mounting surface before drilling begins. Also de-burr the holes and remove any metal shards or remnants. Install grommets into all wire passage holes.**
- **If this manual states that this product may be mounted with suction cups, magnets, tape or Velcro<sup>®</sup>, clean the mounting surface with a 50/50 mix of isopropyl alcohol and water and dry thoroughly.**
- **Do not install this product or route any wires in the deployment area of your air bag. Equipment mounted or located in the air bag deployment area will damage or reduce the effectiveness of the air bag, or become a projectile that could cause serious personal injury or death. Refer to your vehicle owner's manual for the air bag deployment area. The User/Installer assumes full responsibility to determine proper mounting location, based on providing ultimate safety to all passengers inside the vehicle.**
- **For this product to operate at optimum efficiency, a good electrical connection to chassis ground must be made. The recommended procedure requires the product ground wire to be connected directly to the NEGATIVE (-) battery post (this does not include products that use cigar power cords).**
- **If this product uses a remote device for activation or control, make sure that this device is located in an area that allows both the vehicle and the device to be operated safely in any driving condition.**
- **Do not attempt to activate or control this device in a hazardous driving situation.**
- **This product contains either strobe light(s), halogen light(s), high-intensity LEDs or a combination of these lights. Do not stare directly into these lights. Momentary blindness and/or eye damage could result.**
- **Use only soap and water to clean the outer lens. Use of other chemicals could result in premature lens cracking (crazing) and discoloration. Lenses in this condition have significantly reduced effectiveness and should be replaced immediately. Inspect and operate this product regularly to confirm its proper operation and mounting condition. Do not use a pressure washer to clean this product.**
- **It is recommended that these instructions be stored in a safe place and referred to when performing maintenance and/or reinstallation of this product.**
- **FAILURE TO FOLLOW THESE SAFETY PRECAUTIONS AND INSTRUCTIONS COULD RESULT IN DAMAGE TO THE PRODUCT OR VEHICLE AND/OR SERIOUS INJURY TO YOU AND YOUR PASSENGERS!**

**IMPORTANT!** The lightbar should be a minimum of 16" from any radio antennas!

**IMPORTANT!** It is the responsibility of the installation technician to make sure that the installation and operation of this product will not interfere with or compromise the operation or efficiency of any vehicle equipment! Before returning the vehicle to active service, visually confirm the proper operation of this product, as well as all vehicle components/equipment.

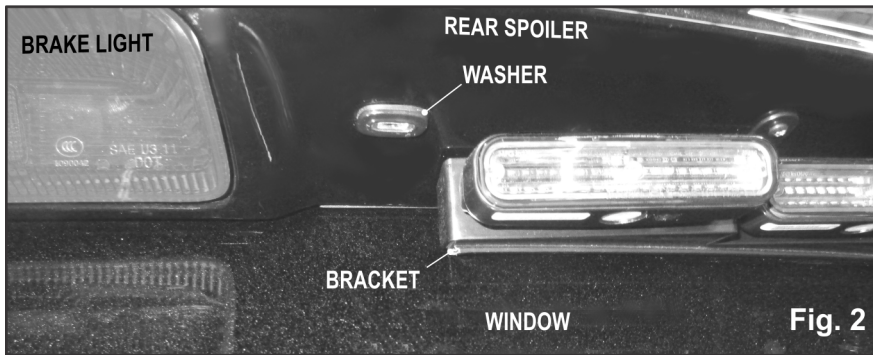


**2014 - 2019 Ford Explorer & 2020 Ford Interceptor SUV:** This lightbar will mount on both the driver and passenger side, on the underside of the rear spoiler.  
**NOTE:** The lightbar pictured is shown here for example. Your lightbar may look different but will mount the same.

**Preparing the spoiler:**

1. Each (half) lightbar will fit between the outer end of the spoiler and the curved indentation towards the inside (Figs. 1 & 2).

2. Mount the rubber trim to each mounting bracket (Fig. 2). Position the passenger side of the lightbar in the exact mounting location with the rubber trim making good contact with the window. Clearly mark the two mounting hole locations onto the spoiler and remove the bracket. Repeat for the driver side of the vehicle.



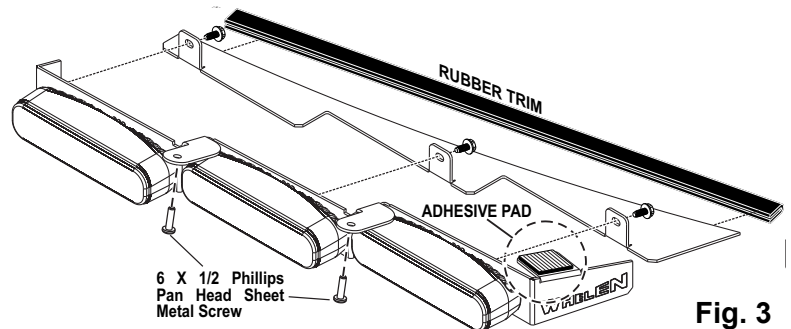
3. Drill pilot holes for the four lightbar mounting holes you marked off in step 2 using a 7/64 drill bit.  
 4. Drill a 7/16 wire access hole in the location indicated in figure 1 on both sides of the vehicle.  
 5. Following factory guidelines remove the spoiler from the vehicle. Install both lightbar wire harnesses into the spoiler following the factory

wire harness. Make sure the end of the lightbar harness with the connectors extends out of the wire hole just enough to connect to the lighthead.

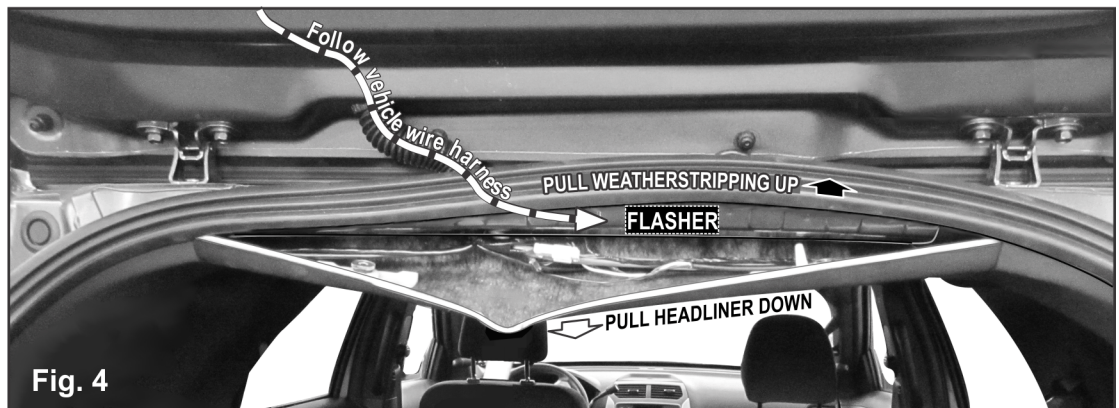
6. **NOTE: Adhesive pad and alcohol wipe not included in 2020 model vehicle.** Plug the wire harness into the lightbar. Before mounting the lightbar use the supplied alcohol pad to clean the area that the adhesive pad on the mounting bracket will adhere to (*Not on 2020*).

7. Peel the paper backing off the adhesive pad on the mounting bracket (*Not on 2020*) and mount the lightbar to the spoiler with the supplied 6 X 1/2 Phillips Pan Head Sheet Metal Screws. Repeat for the opposite side of the vehicle and then reinstall the spoiler to the vehicle following factory specifications.

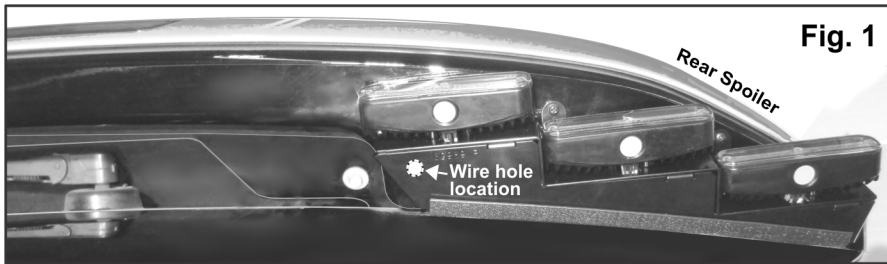
8. Extend the wires to power and make all electrical connections using the information in the Wiring section on page 4. It is suggested that you follow the vehicles factory wiring harness here.



**Fig. 3**



**Fig. 4**

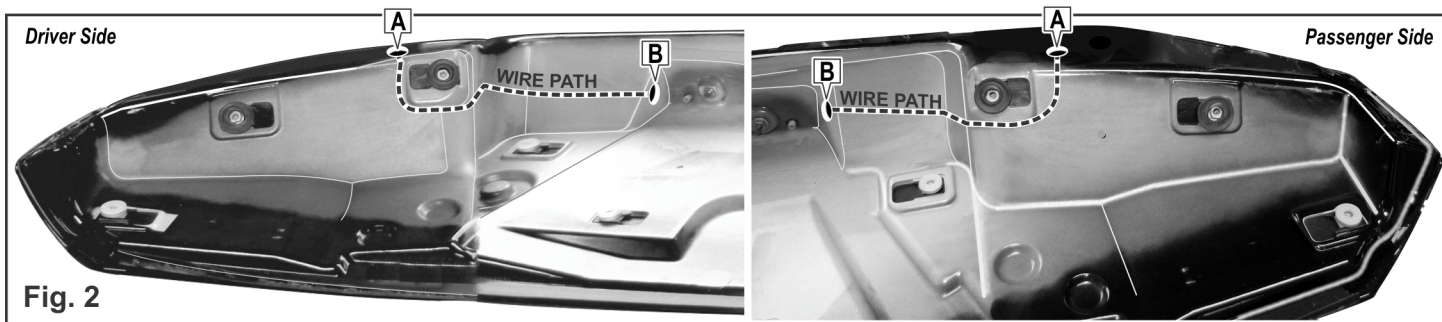


**Fig. 1**

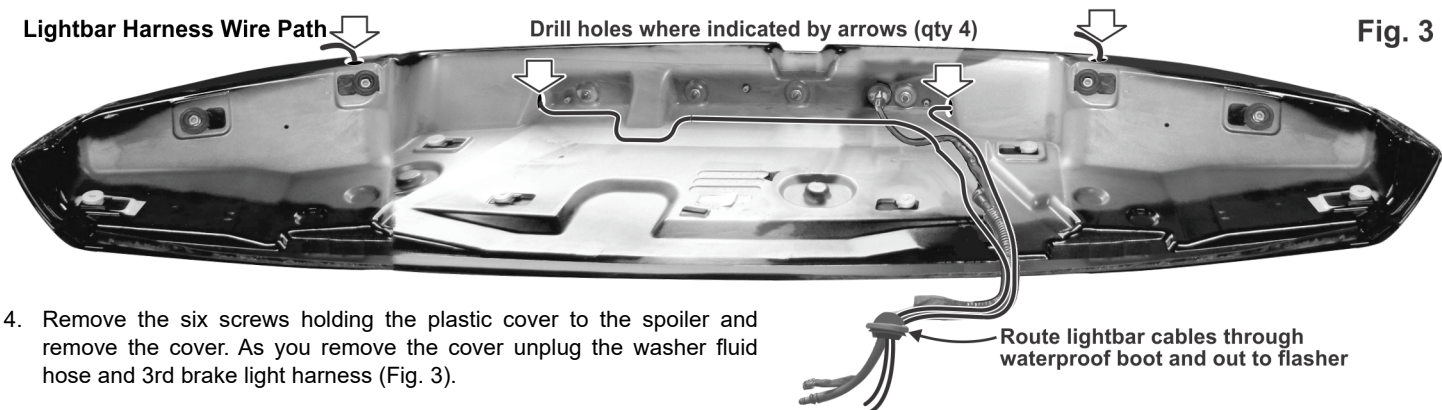
**2014 - 2019 Chevy Tahoe:** This lightbar will mount on both the driver and passenger side, on the underside of the rear spoiler. **IMPORTANT! The lightbar should be a minimum of 16" from any radio antennas!**

**Preparing the Spoiler:**

1. Each (half) lightbar fits between the outer end of the spoiler and the curved indentation towards the inside. Figure 1 shows where the lightbar sits on the vehicle. Position the passenger side of the lightbar in the exact mounting location and clearly mark the two mounting hole locations onto the spoiler. Repeat for the driver side of the vehicle, then (following factory specifications) remove the rear spoiler from the vehicle.
2. To locate where the wire holes are to be drilled refer to figures 1, 2 and 3. Figure 2 shows the spoiler with the plastic cover removed and indicates the four wire hole locations. The location of the wire hole will be directly under the inside lighthouse (Fig. 1). **Before removing the cover**, drill two 7/16" wire holes through both the plastic cover and spoiler in the two locations labeled "A" in Figure 2.
3. Drill pilot holes for the four lightbar mounting holes you marked off in step 1 through both the plastic cover and spoiler using a 7/64 drill bit.

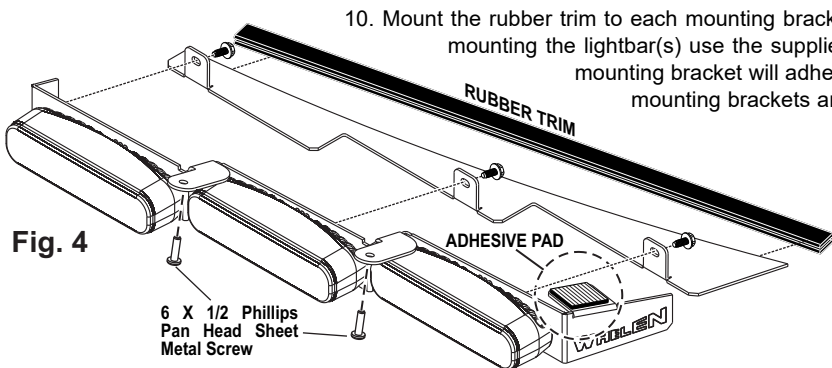


**Fig. 2**



**Fig. 3**

4. Remove the six screws holding the plastic cover to the spoiler and remove the cover. As you remove the cover unplug the washer fluid hose and 3rd brake light harness (Fig. 3).
5. Drill two 7/16" wire holes in the locations in figure 2 labeled "B" and run both wire harnesses through as shown.
6. Extend the two lightbar harness cables toward the bottom of the spoiler following the brake light wire harness. They will follow the brake light wire harness out of the spoiler. Leave just enough harness on the lightbar end, to plug into the lightbar.
7. **In the plastic cover** you removed in step 4 slightly widen the lightbar mounting holes you drilled in step 3 so the cover will not catch on the mounting screws when you install the lightbar. **IMPORTANT! Widen the mounting holes in the plastic cover only! DO NOT widen the mounting holes in the spoiler itself or they will be too large for the mounting screws!**
8. Run the two lightbar cables through the wire holes you drilled and through the waterproof boot (Fig. 3).
9. Plug the washer fluid hose and 3rd brake light harness back in and reinstall the interior trim.



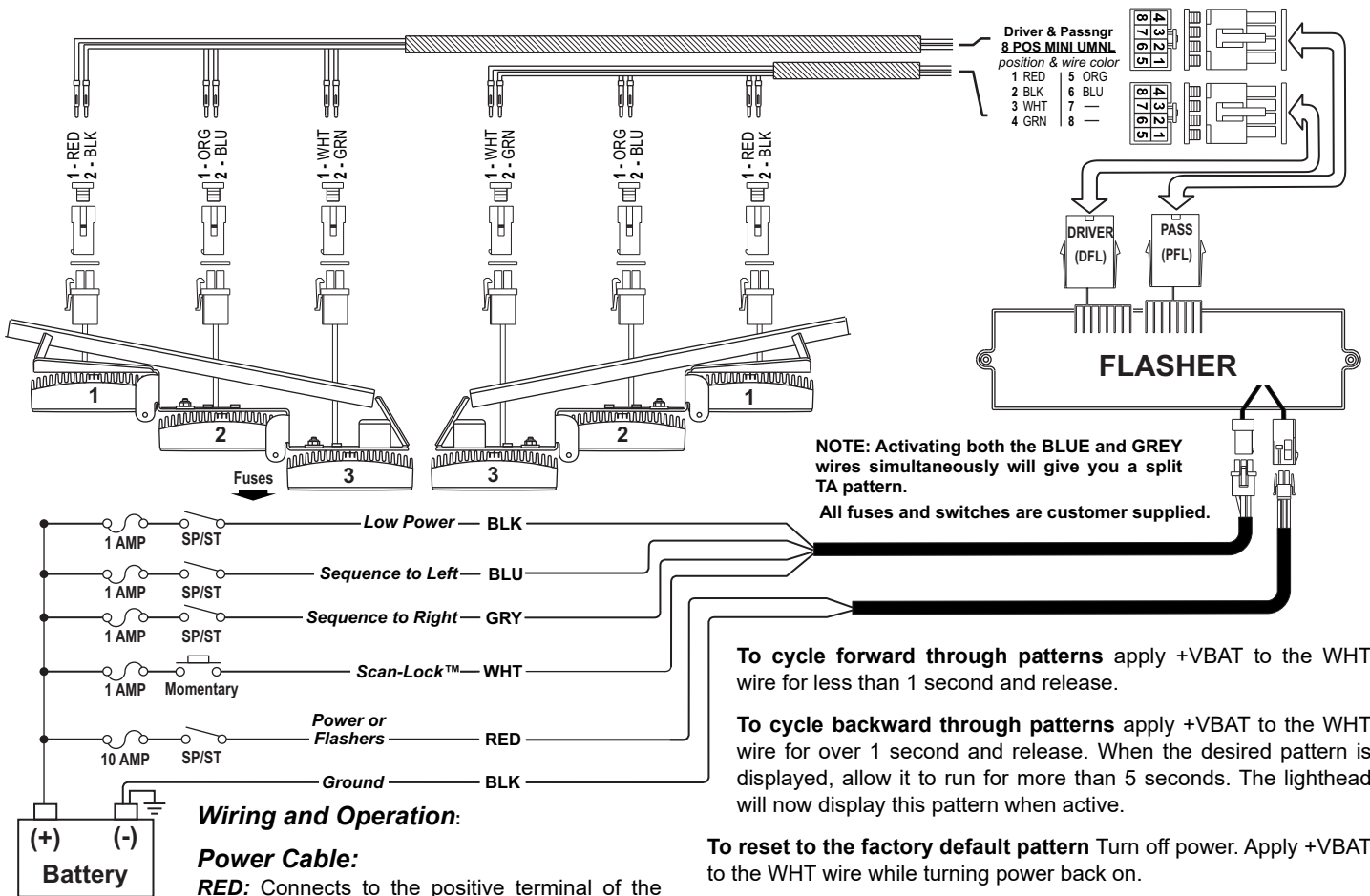
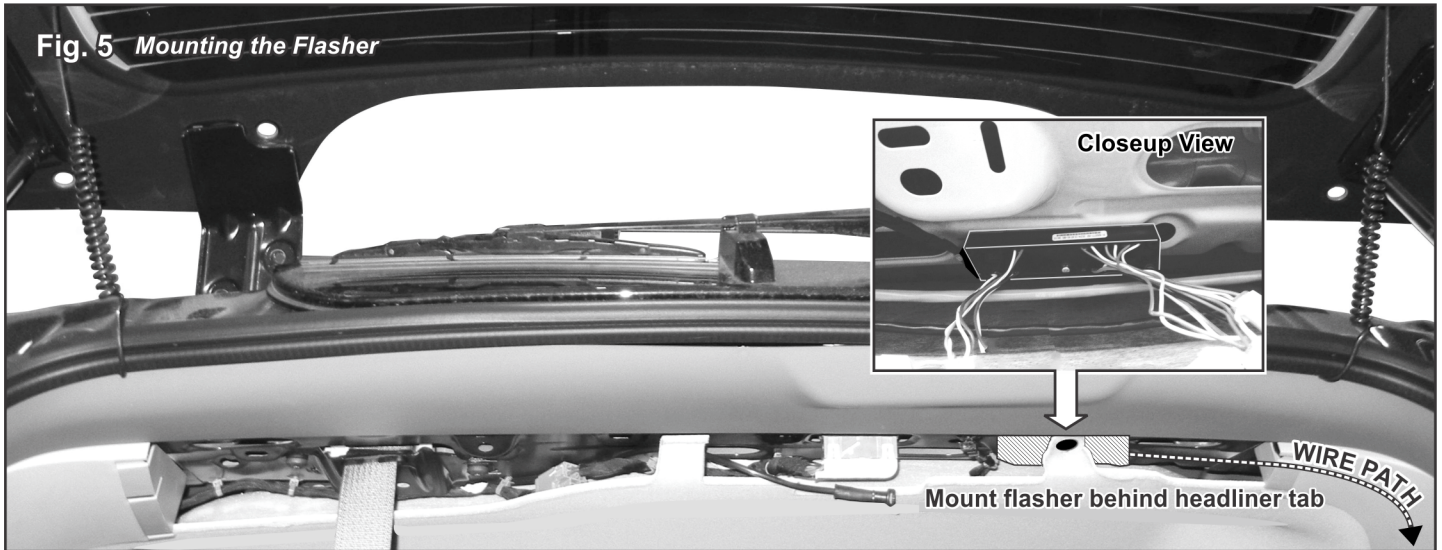
**Fig. 4**

10. Mount the rubber trim to each mounting bracket (where the bracket touches the windshield - Fig. 4). Before mounting the lightbar(s) use the supplied alcohol pad to clean the area that the adhesive pad on the mounting bracket will adhere to. Peel the paper backing off the adhesive pads on the both mounting brackets and mount the lightbar(s) to the spoiler with the supplied 6 X 1/2 Phillips Pan Head Sheet Metal Screws.

11. Reinstall the spoiler to the vehicle and make all electrical connections. Attach the connectors to the wire harnesses and make your connections using the wiring diagram. Wires should follow the vehicle wire harness and extend to the TA flasher.

## Mounting the Flasher / Tahoe:

1. Remove the center plastic panel (Fig. 5) and remove the panel retaining clip holding the headliner as shown.
2. Using the double sided adhesive tape provided, mount the flasher to the vehicle in the position indicated in figure 5 and extend the flasher control cable down the side of the hatch running behind the plastic side panel and to your control panel. Replace the headliner panel retaining clip and plastic trim panel.

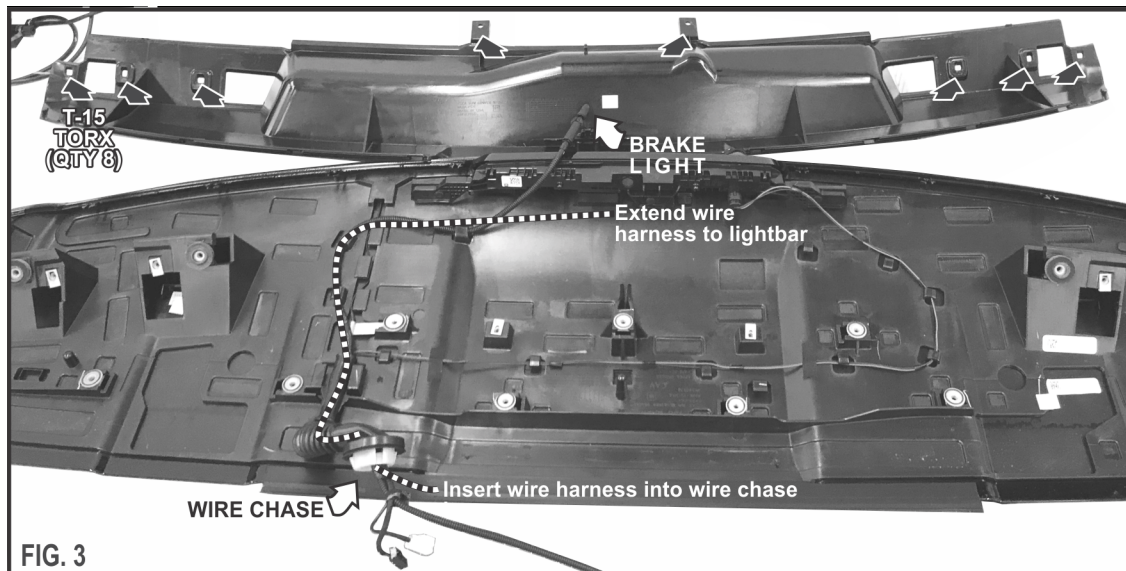


Flash Patterns:		TrafficAdvisor:	
SignalAlert™ 75	SingleFlash 75	SEQ. ON SOLID	1 LAMP TRIPLE FLASH
CometFlash® 75	ActionFlash™	SEQ. ON - SEQ. OFF	2 LAMP TRIPLE FLASH
SingleFlash 300	ActionScan™		
SingleFlash 120			

**BLACK (Low Power):** Apply +VBAT to the BLACK wire to make the lightbar step down to low power and remove voltage for normal operation.

**2021 Chevy Tahoe:** This lightbar will mount on both the driver and passenger side, on the underside of the rear spoiler. **IMPORTANT! The lightbar should be a minimum of 16" from any radio antennas!**

1. Each (half) lightbar fits between the outer end of the spoiler and the curved indentation towards the inside. Place the passenger side housing against rear hatch glass and spoiler, As far to the outside of the vehicle as possible (Fig 1). Position the housing in the exact mounting location and clearly mark the mounting hole locations onto the spoiler. Repeat for the driver side of the vehicle.



2. Remove the eleven T-30 Torx Head screws and the four T-25 Torx head screws that go through the window to remove the spoiler from the vehicle (Fig. 2).
3. With the spoiler removed, Remove the eight T-15 screws that hold the cover on to provide access for cable routing. As you remove the cover unplug the washer fluid hose and 3rd brake light harness (Fig. 3).
4. Drill pilot holes for the lightbar mounting holes you marked off in step 1 through both the plastic cover and spoiler using a 7/64 drill bit.
5. Drill two 7/16" wire holes. It is up to the customer to choose a location that will not cause damage to any lightbar components.
6. Extend the two lightbar harness cables through wire chase toward the bottom of the spoiler following the brake light wire harness (Fig. 3). They will follow the brake light wire harness out of the spoiler. Leave just enough harness on the lightbar end, to plug into the lightbar.
7. Plug the washer fluid hose and 3rd brake light harness back in and reinstall the interior trim.
8. Mount the rubber trim to each mounting bracket (where the bracket touches the windshield - Fig. 4). Before mounting the lightbar(s) use the supplied alcohol pad to clean the area that the adhesive pad on the mounting bracket will adhere to. Peel the paper backing off the adhesive pads on the both mounting brackets and mount the lightbar(s) to the spoiler with the supplied 6 X 1/2 Phillips Pan Head Sheet Metal Screws.
9. Reinstall the spoiler to the vehicle and make all electrical connections. Attach the connectors to the wire harnesses and make your connections using the wiring diagram Wires should follow the vehicle wire harness and extend to the TA flasher.

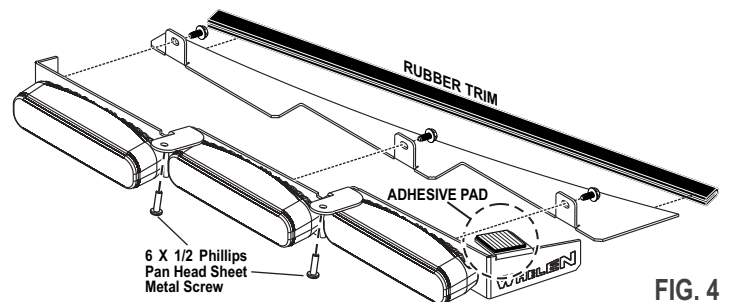


FIG. 4

**BLUE (Sequence to Left):** With the unit activated, applying +VBAT to the BLUE wire causes lightheads to flash, starting at RIGHT and flashing toward LEFT.

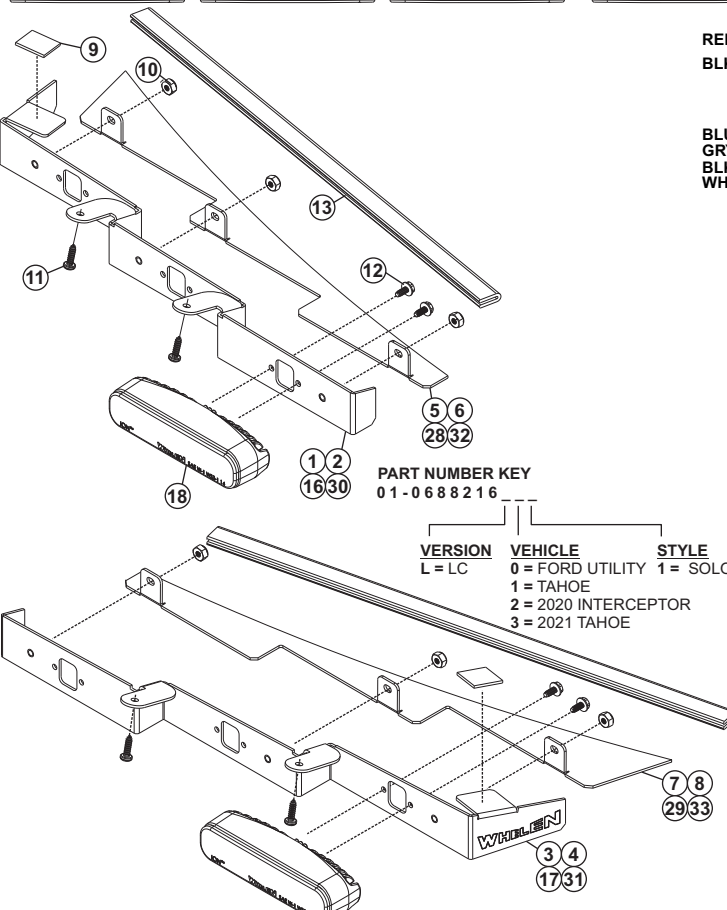
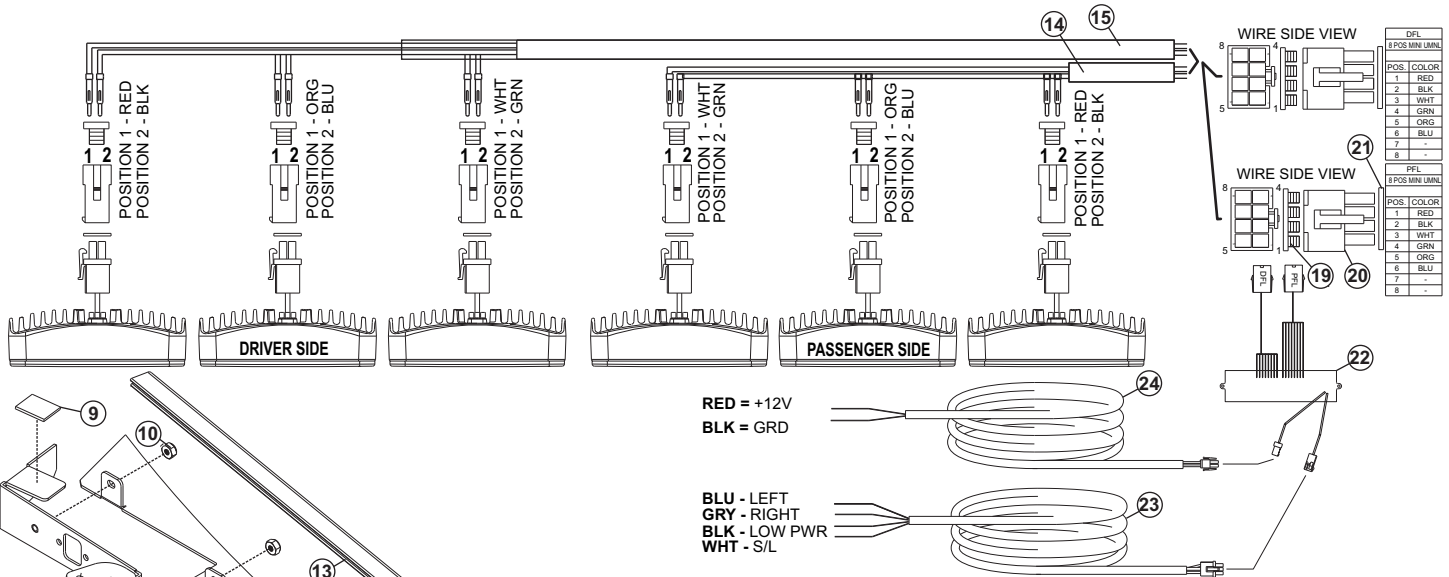
**GREY (Sequence to Right):** With the unit activated, applying +VBAT to the GREY wire causes lightheads to flash, starting at LEFT and flashing toward RIGHT.

**BLUE and GREY (Split T/A):** Activating both the BLUE and GREY wires at the same time will give you a split TA pattern.

**Caution:** Permanent mounting of this product will require drilling. It is absolutely necessary to make sure that no other vehicle components could be damaged by this process. Check both sides of the mounting surface before starting.

**IMPORTANT! It is the responsibility of the installation technician to make sure that the installation and operation of this product will not interfere with or compromise the operation or efficiency of any vehicle equipment! Before returning the vehicle to active service, visually confirm the proper operation of this product, as well as all vehicle components/equipment.**

**IMPORTANT WARNING!**  
**CAUTION! DO NOT LOOK DIRECTLY AT THESE LED'S WHILE THEY ARE ON. MOMENTARY BLINDNESS AND/OR EYE DAMAGE COULD RESULT!**



QTY	QTY	QTY	QTY	ITEM	PART NUMBER	DESCRIPTION
		*			01-0688216L01	ION OUTER EDGE, LC, SOLO, FORD UTILITY
		*			01-0688216L11	ION OUTER EDGE, LC, SOLO, TAHOE
	*				01-0688216L21	ION OUTER EDGE, LC, SOLO, 2020 INTERCEPTOR
*					01-0688216L31	ION OUTER EDGE, LC, SOLO, 2021 TAHOE
-	-	1	-	1	07-288195-023	BRCKT, MTG DRVR ION OUTER EDGE 2014+ TAHOE BLK
-	-	-	1	2	07-288194-023	BRCKT, MTG DRVR ION OUTER EDGE 2014+ FORD UTILITY BLK
-	-	1	-	3	07-288195-123	BRCKT, MTG PASS ION OUTER EDGE 2014+ TAHOE BLACK
-	-	-	1	4	07-288194-123	BRCKT, MTG PASS ION OUTER EDGE 2014+ FORD UTILITY BLK
-	-	1	-	5	11-26G989-007	COVER, DRVR ION OUTER EDGE 2014+ TAHOE BLACK
-	-	-	1	6	11-26G988-007	COVER, DRVR ION OTR EDGE 2014+ FORD UTILITY BLK
-	-	1	-	7	11-26G989-107	COVER, PASS ION OUTER EDGE 2014+ TAHOE BLACK
-	-	-	1	8	11-26G988-107	COVER, PASS ION OTR EDGE 2014+ FORD UTILITY BLK
2	-	2	2	9	66-0416678-00	TAPE, VHB DOUBLE STICK BLACK .062 X 3/4" X 108" 3M4979F
6	8	6	6	10	13-062132-052	NUT, 6-32 ELASTIC STOP BRASS NICKEL PLATE
4	4	4	4	11	15-06121B-082	SCREW, 6 X 1/2 PPHSMS TYPE A 410 SS BLK ZINC OX
12	12	12	12	12	15-018680-056	SCREW, 6 X 5/16 PHIL HWH TFS PLASTITE 48-2 302 SS
2	2	2	2	13	38-0546827-**	TRIM, SEAL HOUSING/WINDSHIELD INNER EDGE XLP
1	1	1	1	14	46-0788212-00	ASSY, CABLE HARNESS 6/C 3' OUTER EDGE
1	1	1	1	15	46-0788212-01	ASSY, CABLE HARNESS 6/C 5' OUTER EDGE
-	1	-	-	16	07-288667-023	BRCKT, MTG DRVR ION OUTER EDGE 2020 FORD UTILITY BLK
-	1	-	-	17	07-288667-123	BRCKT, MTG PASS ION OUTER EDGE 2020 FORD UTILITY BLK
6	6	6	6	18	01-026D816***	SUB ASSY, ION LT 2-WIRE
2	2	2	2	19	39-2H17430-08	SEAL, GANG 8 POS MINI UMNL
2	2	2	2	20	39-0917425-08	HOUSING, PLUG, 2 X 4 POS MINI UMNL, SEALED
2	2	2	2	21	39-2H17429-08	SEAL, INTERFACE 8 POS MINI UMNL
1	1	1	1	22	01-026H084-00	ELEC. ASST, OUTER EDGE FLASHER
1	1	1	1	23	46-0747747-00	ASSY, CABLE INPUT ION OUTER EDGE
1	1	1	1	24	46-0747747-01	ASSY, CABLE POWER ION OUTER EDGE
1	-	1	1	25	66-0117352-00	ALCOHOL, PREP 70 ISOPROPYL
A/R	-	A/R	A/R	26	66-0110008-01	ALCOHOL, ISOPROPYL
4	4	4	4	27	39-2H17430-00	SEAL, CAVITY PLUG 1 POS MINI UMNL
-	1	-	-	28	11-288668-023	COVER, DRVR ION OUTER EDGE 2020 FORD UTILITY BLK
-	1	-	-	29	11-288668-123	COVER, PASS ION OUTER EDGE 2020 FORD UTILITY BLK
1	-	-	-	30	07-288822-023	BRACKET, MTG DRVR 2021 TAHOE ION OUTER EDGE BLK
1	-	-	-	31	07-288822-123	BRACKET, MTG PASS 2021 TAHOE ION OUTER EDGE BLK
1	-	-	-	32	11-26K098-007	COVER, DRVR ION OUTER EDGE 2021 TAHOE
1	-	-	-	33	11-26K098-107	COVER, PASS ION OUTER EDGE 2021 TAHOE